

# Venice

**VE107505GM**

Gunmetal Straight Tower Basin Mixer

All dimensions in mm

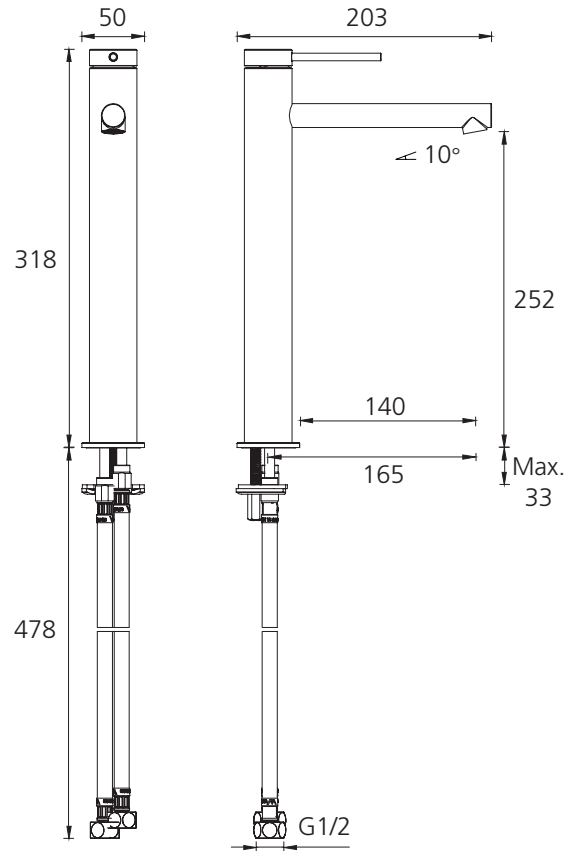

## Specifications /

<b>WELS Rating</b>	5 Star, 6 L per min
<b>Temperature rating (min / max)</b>	1°C - 65°C
<b>Pressure rating (min / max)</b>	Min 150 kPa - Max 500 kPa
<b>Finish</b>	Gunmetal (paint with finger print resistant coating)
<b>Materials</b>	Brass body and zinc handle with SUS handle lever
<b>Cartridge size</b>	25 mm
<b>Cartridge type</b>	Ceramic disc cartridge
<b>Product weight</b>	1.3 kg
<b>Mixer height</b>	318 mm
<b>Water supply</b>	Mains
<b>Warranty</b>	15 years cartridge and body; 5 years finish, seals, tails, fittings, aerators; 1 year labour (see Oliveri website for full details)
<b>Maintenance and care instructions</b>	All surfaces should be cleaned with mild liquid detergent or soap and water. Do not use cream cleaners or citrus based cleaning products, as they are abrasive. Use of unsuitable cleaning agents may damage the surface. Any damage caused in this way will not be covered by warranty.